

Journal of
Physical Sciences
(JPS)

**Evaluation of the Level of Radioactivity of the Samples Taken
From the Mining Squares of the Company Lualaba Mining
Resources Sas**



CARI
Journals

Evaluation of the Level of Radioactivity of the Samples Taken From the Mining Squares of the Company Lualaba Mining Resources Sas

 Jules Lwembe Kimpinde

Degree in analytical chemistry,

Researcher at the General Atomic Energy Commission,

Democratic Republic of the Congo,

Radiation protection consultant.

<https://orcid.org/0009-0001-0016-0376>

Accepted: 21st Dec 2023 Received in Revised Form: 7th Jan 2024 Published: 21st Jan 2024

Abstract

Purpose: This investigation focuses on measuring the radiation levels in mining squares run by the company Lualaba Mining Resources Sas. Worker and environmental exposure to radioactive levels that might be dangerous can result from mining operations. Therefore, the purpose aim this investigation is to assess and gauge radioactivity that exists in these mining areas, as well as to pinpoint its origins and examine the way it may affect occupational and environmental safety. This investigation has significance since Lualaba Mining Resources Sas located near Shinkolobwe, one of the Democratic Republic of the Congo's most important uranium deposits. This uranium resource complicates radiation assessments in Lualaba Mining Resources Sas' mining areas.

Methodology: A variety of samples, including rock, and soil will be taken from the mining squares under consideration as part of the suggested technique used in this investigation. The level of ionizing radiation was measured using radiation detection tools such as Thermo scientific FH40G-L10SN43, Polymaster PM1703GN and HDS101G counters. To assess compliance and possible dangers, the collected data were compared to recognized radiation safety requirements.

Findings: The evaluation's findings show that the radiation levels in the mined squares are higher than background values. The primary causes of radioactivity are thought to be naturally occurring radioactive elements found inside the geological formations being mined. The assessment clarifies the radiation levels in the company's mining areas, emphasizing the need for strict safety regulations to safeguard both employees and the environment.

Unique contributor to theory, policy and practice: The research places a strong emphasis on continual monitoring, personnel training, and the implementation of best practices to reduce any possible health and environmental concerns connected to mining-related radioactivity.

Keywords: *Radioactivity, Mining Squares, Resources Radiation Safety*

1. Introduction

The context of environmental and occupational safety within the mining business, the assessment of radiation levels in samples taken from the mining areas of Lualaba Mining Resources SAS is a crucial undertaking. Natural resources have been utilized by Lualaba Mining Resources SAS, a significant participant in the mining industry, to support industrial development and economic prosperity [1]. Natural radioactive materials exist in the Earth's crust like uranium and thorium, which may be found in a variety of geological formations. These components can provide potential threats to employees, the environment, and local populations when they are disturbed during mining activities. This analysis aims to carefully evaluate the level of radioactivity present in the samples obtained from the mining areas of Lualaba Mining Resources SAS [2]. To protect the health and wellbeing of the company's personnel and to guarantee ethical and sustainable mining methods that comply with legal requirements, it is crucial to accurately measure and grasp the radiation levels contained in these samples. To ensure worker safety, equipment reliability, and environment conservation, it is crucial to comprehend the level of radioactivity within the mining area. Furthermore, for mining firms like Lualaba Mining Resources SAS to operate sustainably, compliance with international safety standards and laws is crucial. This evaluation's importance goes beyond its immediate practical context [3]. It emphasizes the significance of ethical mining for the whole world community, recognizing the need to reduce the negative effects of radioactivity and other possible risks related to mining operations. This thorough assessment highlights Lualaba Mining Resources SAS's dedication to ethical and sustainable mining methods. The organization exhibits its commitment to the well-being of its staff, the preservation of the environment, and compliance with legal requirements by proactively addressing radioactive risks. The significance of assessing radiation levels, possible hazards, and the wider ramifications of this evaluation for Lualaba Mining Resources SAS and the mining sector in general. The evaluation's conclusions and suggestions will help manage mining operations responsibly, connecting them with sustainability objectives while maintaining the safety and wellbeing of all parties involved [4]. In the 1980s, vibration cutting was used in several exploratory experimental studies when extracting coal. Rock breaking, rock mining, and other industries have successfully used vibration cutting and other sectors as a sophisticated energy-saving method. By simulating slicing of the coal sample with single pole teeth, the real mining operation of cutting was replicated. To modify the study in search of a set of combination parameters that might greatly lower reducing energy and electricity use. An extremely high frequency vibration test device was made to examine the viability of the vibration cutting [5]. This study focuses on determining the radioactivity level on samples collected from the mining area run by Lualaba Mining Resources SAS.

2. Related works

The study [6] offered advice on how to create a suitable policy approach that can be implemented as a series of practical measures with a discernible effect on human development. To determine the region of Lualaba's true problems to solve, extensive research has been done. The paper [7] identified and, consequently, quantifies potential future supply

threats. To do this, it examined the case of cobalt using a historical analysis approach developed by federation of German Centre for Geophysics and ordinary Sciences and Volkswagen (BGR-VW). The paper [8] investigated on a regular basis mycorrhizal fungi colonize roots. Additionally, assessed were the yield, the quantity of seeds in each pod, and the number of pods per plant. The findings demonstrated that salts boosted the vegetative characteristics while having a small but substantial effect on the growth characteristics when combined with mycelium infection. The paper [9] quantified the level of natural radon in a few foodstuffs and crop soils from Yemen's Abyan Delta plus to analyze how soil or food communicate by determining the transfer factor (TF). A comparison between the yearly effective dosages for individuals and the baseline levels was also done. The study examined [10] the electromagnetic exposure level and the concentrations of contaminants in shellfish and fish offered for sale in Serbian markets. American fishery goods exported, Asia, and Europe and indigenous fish species were examined. The amount of ^{137}Cs and spontaneous radioactivity were measured using alpha spectrometer. The study [11] used computed tomography with femur single electron emission tomography (SPECT/CT) to build a new analytical appraisal in three dimensions approach for bone metastases. Total bone uptake (TBU), a measure of the load of active bone metastases, was calculated as a total of uptake value (SUV). High levels of metals in natural media make it challenging to analyze the toxicology and behavioral ecology of metal oxide nanoparticles (MONPs). A number of tracking tags can be used to enhance the detection and quantification of MONPs in complicated samples [12]. The study [13] used dual-energy imaging with X-rays based on a photon-counting measurement to determine if the substance is viable breakdown for a pulmonary function test. Xe that is not reactive was employed to identify the breathing area. The study [14] offered a complete collection of techniques for acquiring discontinuous parameters with the help of close-range photogrammetry technology, using a variety of methods. A three-dimensional cloud of points with exceptional accuracy depiction of a situation is produced using reliable geographical data; linear as well as planar changes can be recognized and gathered semi-automatically. The study [15] demonstrated that NPs are significant by-products for both source and recyclable materials derived from the phosphate rock applications. Numerous processes in the fertilizer phosphorus sector are investigated in relation to the chemical et mineralogical layout, size, and reaction of the emission NP. The study [16] described a two-stage biological precipitation process for chemically decontaminating radioactive effluent. The primary radionuclides in the 35 m³ of radioactive wastewater were Cs-137, Cs-134, and Co-60. The liquid waste had an initial radioactive content with regard to Cs-137, Cs-134, and Co-60, of 2264, 17, and 9 Bq/L, respectively. The study [17] investigated, tile specimens were made using four Bayer crimson muds up to 40 weight percent, and the characteristics were assessed in relation to the Chinese National Standard (GB/T4100-2015 China). The development of Fe₂O₃, the primary contaminants, and its significant impact on the characteristics of the samples in their original state were investigated. By measuring the amounts of every element by Instrument Neutron Activation Analysis (INAA) along with comparing the results to the permitted limit, various radiometric and chemical risks indices of fertilizers made from phosphates and the gyp trash were

determined [18]. The paper [19] depended on lowering the density of broken Cooper pairs, or quasiparticle. Here, we demonstrate the importance of ambient radioactivity as a source of no equilibrium quasiparticle. Quantum error correction becomes even more complex by the introduction of ion-induced resonance-chamber time-correlated quasiparticle burst on the same semiconductor. The study [20] carried out to calculate the radioactive content of the food ingested in Fiji and to determine the amount of natural ambient radioactivity. The Fiji's first attempt to look into radioactive levels and assess the amount found in frequently consumed indigenous and foreign food items.

3. Study Area

In this study inquiry is significant because Shinkolobwe, one of the most significant uranium resources in the Democratic Republic of the Congo, is close to Lualaba Mining Resources Sas. Figure 1 shows the Uranium mine images.

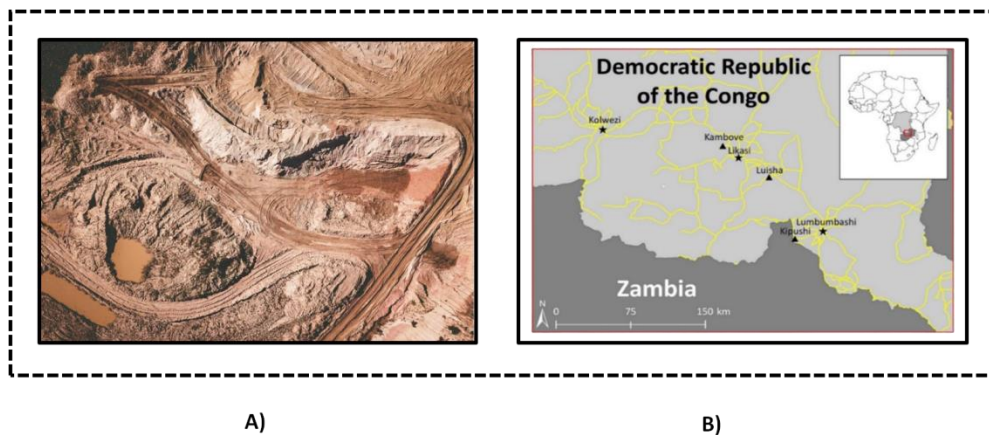

Figure 1: A) Uranium mine images and

B) Democratic Republic of the Congo the yellow line represents the road network

4. Rock and soil vibrations drills using a single level of autonomy approach

The contact among the mineral and the cutting bit is Figure 2. Illustrates how vibratory boring is really carried out in rock and dirt. According to the dynamical properties and vibrating mechanics of resonance the drilling process, a boring bit powered by ultrasound drill into soil and rocks reciprocating. As shown in Figure 2, the assembling of rock and boring bit using the vibrate boring method is a solely open certificate scheme. Here, comparable mass of the movement part in the case of the iron ore motion drilling device in kg; ms is the comparable mass of the hole in the weight of the drilling bit in kg; k, the comparable soil and rock spring stiffness in N/m; and c, the corresponding soil and rock damping factor.

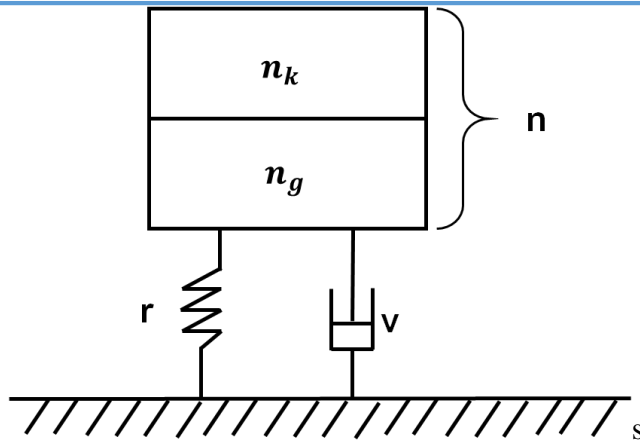

Figure 2: Rock-drilling bit solo-level independence modeling

Essentially, the whole thing made up of the boring bit and the rock that is used in the vibration-induced piercing procedure is a one-degree-of-freedom arrangement in which the movement of y and the induced force $L(\tau)$ are the inputs and outputs, respectively. The difference equation for it is

$$n \frac{t^2 x}{t\tau^2} + v \frac{tx}{t\tau} + rx = L(\tau) \quad (1)$$

In the course of vibrating tapping, the single-freedom degrees' structure of the rock thus the hole bit may be tested by a very brief samples period of time, and these sampling equations can be written as

$$\frac{tx}{t\tau} \Big|_{m\tau_0} = \frac{x(m\tau_0) - x(m\tau_0 - 1)}{\tau_0} \quad (2)$$

$$\frac{t^2 x}{t\tau^2} \Big|_{m\tau_0} = \frac{t}{t\tau} \left(\frac{tx}{t\tau} \right) = \frac{x(m\tau_0) - 2x(m\tau_0 - 1) + x(m\tau_0 - 2)}{\tau_0^2} \quad (3)$$

Equation (1) may be transformed into the subsequent solution by substituting Equations (2) and (3):

$$\left(\frac{n}{\tau_0^2} + \frac{v}{\tau_0} + r \right) x(m\tau_0) - \left(\frac{2n}{\tau_0^2} + \frac{v}{\tau_0} \right) x(m\tau_0 - 1) + \frac{n}{\tau_0^2} x(m\tau_0 - 2) = L(m\tau_0) \alpha = -\frac{2n/\tau_0^2 + v/\tau_0}{n/\tau_0^2 + v/\tau_0 + r} \beta = \frac{n/\tau_0^2}{n/\tau_0^2 + v/\tau_0 + r} \varepsilon = \frac{1}{n/\tau_0^2 + v/\tau_0 + r} \quad (4)$$

And $\varepsilon L(m)$ from Eq. (4), the differential equations for the rock plus boring bit in the single flexibility level framework during vibrating drills may be written as follows:

$$x(m) + \alpha x(m - 1) + \beta x(m - 2) = \varepsilon L(m) \quad (5)$$

Where the correlation between the component values, and the sample time 0 is.

The granite and soil variables in the vibratory boring method may be described as if the quantity of the factors likes as, and might be acquired through detection.

$$n = \frac{\beta}{\varepsilon} \tau_0^2, v = \frac{\alpha + 2\beta}{\varepsilon} \tau_0, r = \frac{1 + \alpha + \beta}{\varepsilon} \quad (6)$$

In the resonant technique for vibrating drills rock, the natural frequency l_x of the soil and rock may be written as

$$l_x = \sqrt{\frac{1+\alpha+\beta}{\varepsilon} \frac{1}{2\pi\tau_0}} \quad (7)$$

As shown in the illustration to help in determining of the rock and soil properties when using the vibration boring method, an extensive range of unexpected intervening factors may be transferred into the result of the oscillating acoustic drilled bit—soil pair to be designated as noises (n). Consequently, the bit rock in the metallic mine's a one-degree of autonomy randomized concept is written as

$$x(m) + \alpha x(m - 1) + \beta x(m - 2) = \varepsilon L(m) + \psi(m) \quad (8)$$

Eq. (8) can be made simpler by rewriting it as Eq. (5) after (n) has been denoised utilizing wavelet-based analysis.

5. Radioactivity Detection

In this study, the level of ionizing radiation is measured using specialized radiation detection tools like the Thermo Scientific FH40G-L10SN43, Polymaster PM1703GN, and HDS101G counters.

a) FH40G-L10SN43

The Thermo Scientific FH40G-L10SN43 is a versatile radiation detection instrument designed for the measurement and monitoring of ionizing radiation, including alpha, beta, gamma, and X-rays. This device can provide real-time measurements of radiation levels in various units, such as counts per minute (CPM), counts per second (CPS), microsieverts per hour ($\mu\text{Sv/h}$), or mill roentgens per hour (mR/h). The FH40G-L10SN43 is typically used for radiation safety inspections, environmental monitoring, and radiological assessments in industries like nuclear power, Health care, and emergency response.

b) Polymaster PM1703GN

The Polymaster PM1703GN is a portable radiation detection device capable of detecting both gamma and neutron radiation. These devices are commonly employed by first responders, border security personnel, and customs officials to identify potential radioactive threats, including nuclear materials that might be used for illicit purposes. The PM1703GN can provide real-time readings of radiation levels, and some models may have alarms to alert users to elevated radiation levels.

c) HDS101G

The HDS101G is a handheld gamma radiation detector. It is designed for the measurement and monitoring of gamma radiation levels in various environments. HDS101G devices are often used in radiation protection, industrial radiography, and nuclear medicine applications.

These devices are essential tools for ensuring radiation safety, conducting environmental assessments, and monitoring potential radiation hazards. Users should receive proper training

in their operation, as well as adhere to safety guidelines and regulations when working with ionizing radiation. The specific features and capabilities of each device may vary depending on the manufacturer and model, so it's important to consult the user manuals and documentation provided by the manufacturer for detailed instructions and specifications.

6. Result and Discussion

The investigation conducted at Lualaba Mining Resources Sas mining squares near Shinkolobwe has yielded significant results regarding the radiation levels in the area. The primary purpose of this study was to evaluate and measure radioactivity levels in these mining areas, identify their origins, and assess their potential impact on occupational and environmental safety. Radiation protection zones are established to ensure the safety of individuals working with or near ionizing radiation sources. These zones are defined based on dose limits recommended by legislation and international radiation protection standards. The tables 1 give the dose limits which make it possible to classify the radiation protection zones as recommended by the legislation.

Table 1 : Subdivision of Zones according to dose rates.

Area type	effective dose likely to be received	dose to be	Maximum dose equivalent rate (H')	equivalent (He)	rate
Room adjoining monitored and controlled areas	<80 μ Sv / month	-	-	-	-
guarded area	<7,5 μ Sv on 1h	-	-	<0,2mSv on 1h	-
controlled area green	7,5 μ Sv < E < 2,5 μ Sv on 1h	-	-	0,2 < He < 0,65mSv on 1h	-
controlled area yellow	<2mSv on 1h	-	<2mSv/h	<50mSv on 1h	-
controlled area Orange	<100mSv on 1h	-	<100mSv/h	<2,5Sv on 1h	-
controlled area Red	>or = 100mSv on 1h	-	> or = 100mSv/h	> or 2,5 Sv on 1h	-

E: effective dose;

He: equivalent dose extremities (hands, forearms, feet, ankles);

H': maximum dose equivalent rate.

Workers who are exposed to ionizing radiation are often classified based on their annual absorbed doses which are shown in table 2. This classification helps ensure that appropriate radiation protection measures are applied and those individuals receive the necessary monitoring and medical attention when required.

Table 2: Classification of workers according to annual absorbed doses

Effective mSv/an	Dose	1				6		20	
		Public area	guarded area	Controlled area	spéciallyrestricted area	restricted area			
Authorized workers			A et B	A B			A		

Radiation protection in any industry, especially in environments with elevated radiation levels like mining operations near uranium deposits, is of paramount importance to ensure the safety of workers and minimize potential health risks. One essential aspect of radiation protection is classifying workers based on their annual absorbed doses. This classification helps in monitoring and regulating radiation exposure, allowing for appropriate safety measures to be implemented.

The use of "Table 3-6" implies that the recorded measurements are organized in a tabular format within a report.

Table 3: Measurements taken at terminal XIII

BF: 0, 11 μ Sv/h

Tickheaded XIII	D° at 1m	D° on contact	DAA
Southern Flak	0,15 μ Sv/h	0,21 μ Sv/h	0,42 μ Sv/h
NorthFlanc	0,11 μ Sv/h	0,17 μ Sv/h	0,34 μ Sv/h
Eastern Flank	0,18 μ Sv/h	024 μ Sv/h	0,48 μ Sv/h
Est Flank	0,19 μ Sv/h	0,20 μ Sv/h	0,40 μ Sv/h

Legend:

- D°: Dose rate;
- AAD. Zone: Annual Absorbed Dose;
- A: Includes the following functions: Mining Engineers, Geologists, Works Supervisors, Heavy Machinery Drivers, Drilling and Mining Personnel, Samplers (mines) and Guard/Guard Police.

6.1 Measurements at storage embankments

Table 4: measurements taken

Places	D° At 1 M	D° on CONTACT	DAA
embankments 1	0,18 $\mu\text{Sv/h}$	0,20 $\mu\text{Sv/h}$	0,40 $\mu\text{Sv/h}$
embankment 2	0,16 $\mu\text{Sv/h}$	0,25 $\mu\text{Sv/h}$	0,50 $\mu\text{Sv/h}$
embankment 3	0,12 $\mu\text{Sv/h}$	0,24 $\mu\text{Sv/h}$	0,48 $\mu\text{Sv/h}$
embankment 4	0,12 $\mu\text{Sv/h}$	0,26 $\mu\text{Sv/h}$	0,52 $\mu\text{Sv/h}$
	0,14 $\mu\text{Sv/h}$	0,24	0,48 $\mu\text{Sv/h}$
embankment 5	0,14 $\mu\text{Sv/h}$	0,25 $\mu\text{Sv/h}$	0,5 $\mu\text{Sv/h}$

6.2 Samples Measurement

Table 5 : Measurement taken

Samples	dose rate	DAA
of 45 meters	0,26 $\mu\text{Sv/h}$	0,52 $\mu\text{Sv/h}$
of 80 meters	0,46 $\mu\text{Sv/h}$	0,92 $\mu\text{Sv/h}$
of 87 meters	0,60 $\mu\text{Sv/h}$	1,20 $\mu\text{Sv/h}$

6.3 Measurement at drill level

Table 6 : Measurements taken

Drilling machine	Dose rate	DAA
drilling n°1	0,18 $\mu\text{Sv/h}$	0,36 $\mu\text{Sv/h}$
drilling n°2	0,15 $\mu\text{Sv/h}$	0,30 $\mu\text{Sv/h}$

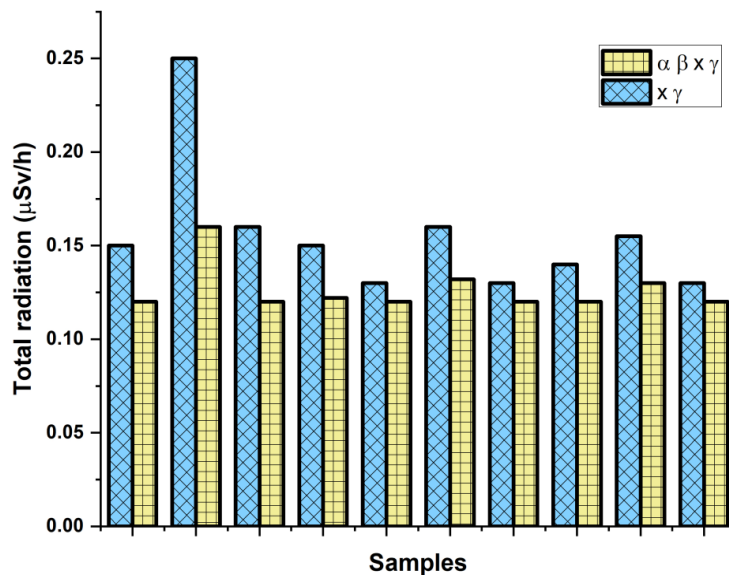

Figure 3: Radioactivity detection of tailing yard in the mining areas.

Figure 3 shows the graph of radio activity detection by utilizing the samples. Radioactivity detection is the process of identifying and measuring the presence of radioactive materials and the level of radiation they emit. This detection is crucial for various purposes, including environmental monitoring, nuclear safety, medical diagnostics, and industrial applications.

7. CONCLUSION

The results of this examination investigating the radiation levels in mining areas run by Lualaba Mining Resources Sas close to Shinkolobwe, the uranium-rich region of the Democratic Republic of the Congo, have substantial ramifications for both occupational and environmental safety. The study evaluated the radioactivity present in these mining regions using a variety of radiation detection techniques, including the Thermo scientific FH40G-L10SN43, Polymaster PM1703GN, and HDS101G counters. The main causes of this increased radioactivity are thought to be naturally existing radioactive components found in the geological formations being mined. In summary, radiation safety in mining operations entails categorizing people according to their job duties and probable radiation exposure, establishing annual absorbed dose limits, and putting in place certain safeguards at crucial places. Adherence to international radiation safety standards, continuous monitoring, and robust training programs are essential to ensure the safety and well-being of workers and the surrounding environment in areas with elevated radiation levels like the Shinkolobwe region. Maintaining a strong commitment to radiation protection, Lualaba Mining Resources Sas and similar mining companies can strike a balance between resource extraction and the safety of their workers and the environment. We recommend reducing the time spent in front of the products in order to minimize exposure, because people who work in ore quarries in addition to those in uranium are considered members of the public and must not exceed the effective dose of 1mSv/ year, below is the maximum time to spend in front of radioactive sources (natural radioactivity) depending on the dose rate emitted in a day.

Future studies should aim to provide a comprehensive understanding of the challenges and solutions related to radiation safety in mining, contributing to safer working conditions and reduced environmental impacts in regions with naturally occurring radioactive materials.

REFERENCE

1. Attallah, M.F., Metwally, S.S., Moussa, S.I. and Soliman, M.A., 2019. Environmental impact assessment of phosphate fertilizers and phosphogypsum waste: elemental and radiological effects. *Microchemical Journal*, 146, pp.789-797.
2. Cardani, L., Valenti, F., Casali, N., Catelani, G., Charpentier, T., Clemenza, M., Colantoni, I., Cruciani, A., D'Imperio, G., Gironi, L. and Grünhaupt, L., 2021. Reducing the impact of radioactivity on quantum circuits in a deep-underground facility. *Nature communications*, 12(1), p.2733.
3. Deline, A.R. and Nason, J.A., 2019. Evaluation of labeling methods used for investigating the environmental behavior and toxicity of metal oxide nanoparticles. *Environmental Science: Nano*, 6(4), pp.1043-1066.
4. El-Gamal, H., Hussien, M.T. and Saleh, E.E., 2019. Evaluation of natural radioactivity levels in soil and various foodstuffs from Delta Abyan, Yemen. *Journal of Radiation Research and Applied Sciences*, 12(1), pp.226-233.
5. Eom, J., Kim, B., Kim, W. and Lee, S., 2018. Evaluation of material decomposition for pulmonary function test in spectral computed tomography: A Monte Carlo simulation study. *Optik*, 174, pp.409-415.
6. Malik, A.Q. and Kumar, A., 2019. Monitoring of Environmental Radioactivity in Foodstuff in Fiji. *International Journal of Science and Research*, 8, pp.1781-1785.
7. Manikanda Bharath, K., Natesan, U., Chandrasekaran, S. and Srinivasalu, S., 2022. Determination of natural radionuclides and radioactive minerals in urban coastal zone of South India using Geospatial approach. *Journal of Radio analytical and Nuclear Chemistry*, 331(5), pp.2005-2018.
8. Milenkovic, B., Stajic, J.M., Stojic, N., Pucarevic, M. and Strbac, S., 2019. Evaluation of heavy metals and radionuclides in fish and seafood products. *Chemosphere*, 229, pp.324-331.
9. Osmanlioglu, A.E., 2018. Decontamination of radioactive wastewater by two-staged chemical precipitation. *Nuclear Engineering and Technology*, 50(6), pp.886-889.
10. Patrick, M.M., 2022. Development of a Downstream Beneficiation Strategy in an underdeveloped Country: Case Study of the Lualaba Province in the Democratic Republic of Congo (Doctoral dissertation, Faculty of Engineering and the Built Environment, University of the Witwatersrand, Johannesburg).
11. Patrick, M.M., 2022. Development of a Downstream Beneficiation Strategy in an underdeveloped Country: Case Study of the Lualaba Province in the Democratic

- Republic of Congo (Doctoral dissertation, Faculty of Engineering and the Built Environment, University of the Witwatersrand, Johannesburg).
12. Patrick, M.M., 2022. Development of a Downstream Beneficiation Strategy in an underdeveloped Country: Case Study of the Lualaba Province in the Democratic Republic of Congo (Doctoral dissertation, Faculty of Engineering and the Built Environment, University of the Witwatersrand, Johannesburg).
 13. Piçarra, A., Annesley, I.R., Otsuki, A. and de Waard, R., 2021. Market assessment of cobalt: Identification and evaluation of supply risk patterns. *Resources Policy*, 73, p.102206.
 14. Piçarra, A., Annesley, I.R., Otsuki, A. and de Waard, R., 2021. Market assessment of cobalt: Identification and evaluation of supply risk patterns. *Resources Policy*, 73, p.102206.
 15. Silva, L.F., Oliveira, M.L., Crissien, T.J., Santosh, M., Bolivar, J., Shao, L., Dotto, G.L., Gasparotto, J. and Schindler, M., 2022. A review on the environmental impact of phosphogypsum and potential health impacts through the release of nanoparticles. *Chemosphere*, 286, p.131513.
 16. Tshibangu Kazadi, A., Baert, G., Lwalaba wa Lwalaba, J., Kirika Ansey, B., Haesaert, G. and Mukobo Mundende, R.P., 2020. Erhöhung der NPK-Düngereffizienz durch arbuskuläre Mykorrhiza in der Gartenbohne (*Phaseolus vulgaris* L.). *Gesunde Pflanzen*, 72, pp.303-310.
 17. Umeda, T., Koizumi, M., Fukai, S., Miyaji, N., Motegi, K., Nakazawa, S. and Takiguchi, T., 2018. Evaluation of bone metastatic burden by bone SPECT/CT in metastatic prostate cancer patients: defining threshold value for total bone uptake and assessment in radium-223 treated patients. *Annals of Nuclear Medicine*, 32, pp.105-113.
 18. Xu, W., Zhang, Y., Li, X., Wang, X., Ma, F., Zhao, J. and Zhang, Y., 2020. Extraction and statistics of discontinuity orientation and trace length from typical fractured rock mass: A case study of the Xinchang underground research laboratory site, China. *Engineering Geology*, 269, p.105553.
 19. Xu, X., Song, J., Li, Y., Wu, J., Liu, X. and Zhang, C., 2019. The microstructure and properties of ceramic tiles from solid wastes of Bayer red muds. *Construction and Building Materials*, 212, pp.266-274.
 20. Yang, Z., Zhu, L., Zhang, G., Ni, C. and Lin, B., 2020. Review of ultrasonic vibration-assisted machining in advanced materials. *International Journal of Machine Tools and Manufacture*, 156, p.103594.

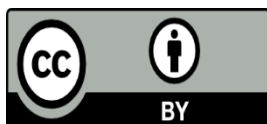

©2023 by the Authors. This Article is an open access article distributed under the terms and conditions of the Creative Commons Attribution (CC BY) license (<http://creativecommons.org/licenses/by/4.0/>)