

# International Journal of Technology and Systems (IJTS)

**A COMPONENT-BASED SIGMA-QUALITY IMPROVEMENT  
MODEL FOR EFFECTIVE SIGNAL DETECTION IN  
COMMUNICATION NETWORKS**



## **A component-based sigma-quality improvement model for effective signal detection in communication networks**

<sup>1\*</sup>Dr Wasiu. Lawal

Electrical and Electronics Engineering Department, Federal University of Technology, Akure, Nigeria

\*Corresponding Author's Email: [amiruawwal@gmail.com](mailto:amiruawwal@gmail.com)

<sup>2</sup>Dr E.O. Ogunti

Electrical and Electronics Engineering Department, Federal University of Technology, Akure, Nigeria

<sup>3</sup>Dr W.O. Apena

Electrical and Electronics Engineering Department, Federal University of Technology, Akure, Nigeria

<sup>4</sup>Prof B. Kareem

Mechanical Engineering Department, Federal University of Technology, Akure, Nigeria

<sup>5</sup>Dr S. O. Olatunji

College of Computer Science and Information Technology, Imam Abdulrahman Bin Faisal University, Dammam, Kingdom of Saudi Arabia

<sup>6</sup>Dr W. O. Oluyombo

Electrical and Computer Engineering Department, Ahmadu Bello University, Zaria, Kaduna, Nigeria

<sup>7</sup>Dr T. Ewetumo

Physics and Electronics Department, Federal University of Technology, Akure, Nigeria

### **Abstract**

**Purpose:** There are many algorithms and models that are successfully utilized in controlling noises and preventing signal fading in communication networks. Signal strength enhancement studies that utilize component-based quality improvement algorithm are not common.

**Methodology:** A signal detection algorithm was developed using the component-based sigma quality improvement flow system. The algorithm was implemented on MATLAB computer programming software.

**Findings:** The algorithm/model was capable of filtering out noises and optimizing RF-signal detection in communication networks. The signal detection results showed super-improved signal Energy to Noise Ratio (ENR) on the balanced probability basis.

**Unique contribution to theory, practice and policy:** Introduction of component-based sigma quality improvement algorithm is an added advantage over the traditional techniques thereby enhancing further fading reduction in communication networks

**Keywords:** *Signal, Noise, Detection, Sigma-quality algorithm, Communication networks*

## 1.0 INTRODUCTION

Signal alerts from the mobile phones tend to cause distortion and distractions in communication networks related to multiple users (Lawal *et al.*, 2014). This dissatisfactory phenomenon has made the use of mobile phones strictly forbidden in some public places (Lawal *et al.*, 2013). Noise emanated from communication signal alerts could be illegal in many countries, even when confined to privately owned spaces or secure facilities (Lawal and Ogunti 2012a). Unauthorized cell phone signals can be effectively monitored using efficient and accurate signal detector in order to minimize probability of false alarm (Kay, 1998; Van, 2001; Kay, 1993). The presence of noise in signals is responsible for fading/interference (Adewuyi *et al.* 2013a, 2013b; Lawal *et al.*, 2014a) and detection inaccuracy (Kailath, and Poor 1998; Tandra, 2005, Lau, 2008). Effective communication networks demand the removal of these noises (Kailath, and Poor 1998; Vaseghi 2000; Vaseghi and Rayner, 1990). Many studies were carried out on minimizing noises in communication networks. The techniques utilized include detection-interpolation scheme (Vaseghi and Rayner, 1990), penalty function technique (Kundu, 2000), minimax noise variance estimation (Shevlyakov and Kim, 2005), improved nonlinear detector (Saberli and Amindavar, 2007), nonparametric dynamic model (Turner, 2009), synthetic antenna array concept (Broumandan, 2009), sparsity hypotheses algorithm (Pastor and Socheleau, 2012), interference cancellation architecture (Chaouech and Bouallegue, 2012), Dynamic Spectrum Access (DSA,) (O'Shea *et al.*, 2014), orthogonal frequency division multiplexing scheme (Adewuyi *et al.* 2013a, 2013b; Lawal *et al.*, 2014a) and a comparative analysis of different outlier detection techniques in cognitive radio networks with malicious users (Arshed *et al.*, 2020).

### 1.1 Background of the study

Based on the stated efforts among others (O'Shea *et al.*, 2014) (Nicholas, 2011; Dece, 2012; Lawal, 2102), there are no identified studies that applied component-based sigma-quality improvement approach for minimization of noises in communication networks. Sigma quality focuses on reducing process variation from the standard. The sigma quality statistics enhances process control by trying to making the system accurate and/or error free (Kareem, 2015; OEC, 2015). In the context of detection study, the focus is to identify and design circuitry components that are responsible for signal detection such that it will provide precise, accurate and error free results. The emerging signal detector from sigma quality assignment would lead to improvement in probability of cell-phone signal detection. Past studies have shown that sigma quality statistic is similar to that of detection analysis using hypothesis test as variation tool (Pyzdek, 2003; Kareem, 2015; OEC, 2015; Kareem and Jewo 2015). There are six improvement levels of sigma-quality technique namely one-, two-, three-, four-, five-, and six-sigma (Pyzdek, 2003; Kareem, 2015; OEC, 2015; Kareem and Jewo 2015; Hadi-Vencheh, and Yousefi, 2018). In this case one-sigma is the lowest (lowest error free) while six-sigma is the highest (highest error free) system. The choice of sigma components depends on the levels of resources and technological advancement at disposal; however, there is need to strike a balance between the two extreme levels.

## 1.2 Statement of the Problem

There is an increase in the hidden use of cellular phone to perpetrate different type of crime. Effort and energy have been spent on detecting unauthorized usage of phones. The ability to locate and detect the source of interruptive signal appears to be a challenge. There should be a noble technique(s) to develop optimal position sensor/circuitry with affinity to detect and locate mobile phone accurately with minimum fading. This study takes advantages of known signal attributes, signal strength and signal quality to develop a better technique (component-based sigma quality) other than traditional approach to eliminate detection errors due to presence of uncommon fading.

## 1.3 Justification of the study

The initial studies could not establish choice of components based on sigma-quality approach (Ogunti *et al.*, 2015a, 2015b). However, accurate detection of mobile phone signals through evolution of improved position sensor /position circuitry is required to enhance minimization of non-detection, miss detection and false alarm ( $F_A$ ) thereby reducing risk of not meeting the system reliability target. This can be achieved through optimal choice of circuitry component detector, unique techniques and suitable algorithm. This study focused on developing component-based robust models for mobile phone signal sensor towards optimal detection and location estimation through mobile device(s) under known noise environment.

## 1.4 Hypothesis

The study adopted noise filtering algorithm/model towards development of sigma-quality strategy using empirical data obtained from a locally fabricated cell-phone signal detector. The focus of this study is to ascertain sigma-quality level(s) of the designed detector; and find out opportunities of obtaining a more precise, accurate and reliable cell-phone signal detector with minimum possible standard level of quality technology.

## 2.0 LITERATURE REVIEW

### 2.1 Theoretical approach

#### 2.1.1 Design of Cell-Phone Sensor Elements

Study mimic detection technique utilized by U.S department of energy (DoE) by measuring a cell phone's electromagnetic properties and determining an identifiable signature such as the RF spectrum around 240 - 400 MHz (outside the- cellular phone band). Spurious emissions from cellular phones are monitored and recorded (US DoE, 2007) when the phone is transmitting. Alternative cell phone detector operating on RF frequency 900MHz-1800MHz was developed from previous designs to address the detection accuracy challenges (Lawal, 2012). Improving robustness of detector, resistance to loss of cell-phone signal detection with any small change in signal/noise parameters, at reduced cost of risk of failing to meet signal target ( $F_A$ ) was a good focus(Ogunti *et al.*, 2015a, 2015b). The position sensor was developed, other reserved areas that were examined are the evaluation of the robustness of signal detection in terms of detects and false alarms of the cell phone and the estimation of the phone position. The study addressed challenges stated through application sigma improvement approach.

### 2.1.2 Cell-Phone Positioning Sensor

A cell phone detector that can detect signals used in GSM band at about 900 MHz and Digital Cellular System (DCS) at about 1800MHz (Lawal, 2012) was developed. Mobile phone signals are digitally encoded; it can detect only signal activity, not speech or message contents. Detector unit consists of a dipole antenna, capacitors, resistors, transistor, diode and an operational amplifier (Lawal, 2012). Antenna receives the GSM signals in media, and then a small amount of charge is induced in the capacitor, diode demodulates and brings signal detection. (Wannurul, 2011, Lawal and Ogunti, 2013). Improvement management strategy on components responsible for robust removal of noise in communication networks. This study is based on customized device (detector) (not inbuilt on the mobile phone), a separate device that have affinity to detect and locate mobile phone around by utilizing signal attributes SS and SQ from mobile phone operating around it to predict the actual position/s of the phone. Studies have attempted to optimize the robustness of detection strategies in sonar, communications (digital and analogue systems), seismic, radar, speech, image analysis, biomedicine and control systems (Kay, 1998; Vaseghi, 2000). The optimization efforts in the areas of mobile phone signal detection and location are limited. Mobile phone signal detectors previously developed are not taking cognizance of optimizing accuracy, precision, phone location and robustness of detection through improvement on critical components responsible for detection and location. This study addressed the limitations of previous studies. Approach that takes care of high precision in detection components and the risk of not meeting the target was precious in determining and optimizing the robustness of detecting and locating mobile phone signals. An approach based on Bayesian reasoning has been deployed in this direction to address gaps in the previous studies. The achievement of accurate detection could attract high techniques but low risk of missing the expected target. As the accuracy is becoming low, the system detection failure could be high. The optimal (robust) detection system was based on the tradeoff between accurate detection (hits) and false detection (false alarm,  $F_A$ ) under known noise (Kay, 1998; Van, 2001, Ogunti *et al.*, 2015a, 2015b). There are various approaches to be deployed to accurately detect mobile phone position. In recent times, efforts are made using received location fingerprint (SS and SQ) and compared to conventional location method explored (Kaemarungsi and Krishnamurthy, 2004; Kaemarungsi, 2006; Tsai *et al.*, 2009; Mantoro and Olowolayemo, 2009 and Mantoro *et al.*, 2011). The initial study on sigma quality on devices failed to consider detection accuracy as indices of reliability. This work determines robustness of noise removal in communication system by taking advantage of known signal strength (SS) and signal quality (SQ) through modeling using sigma improvement quality algorithms. Prediction accuracies are usually affected by the techniques and devices (components) used as well as the algorithms applied (Mantoro *et al.*, 2011). The appropriate management of these components for prediction accuracy has been a major challenge in location prediction.

### 2.2 Basic concept of techniques deployed for the study

Major technique deployed in this study to investigate the level of noise removal in the developed circuitry system involved Sigma-Quality Statistics/Improvement Strategy/Sigma Quality Analyses (SQA).

### 2.2.1 Sigma-Quality Statistics/ Improvement Strategy

Sigma quality approach is based on process control system targeting zero error tolerance components refinement. Sigma quality statistics entails sigma one to sigma six with the latter being the highest obtainable continuous improvement level which allows about three errors in a million components, with value varies from 0.69, 0.31, 0.067, 0.0062, 0.00023, 0.0000034 (Pyzdek, 2003; Tauseef, 2012 and Kareem 2015). The quality statistics has been found useful in detection analyses (Ogunti *et al.*, 2015a). Previous studies on detection in communication system utilizing quality improvement strategy revealed significant improvement in signal detection through improved signal energy-to-noise ratio (ENR) and probability of detection ( $P_D$ ) and reduction in probability of false alarm ( $P_{FA}$ ) (Ogunti *et al.*, 2015b) did not consider each of the component reliability made up detection sensor.

**3.0 Research Methodology** The conceptual design block diagram (Figure 1) showed the relationships among system elements of signal detection enhancement circuitry. This was developed to take care of knowledge gaps from the initial studies through incorporation of system component improvement circuitry strategy.

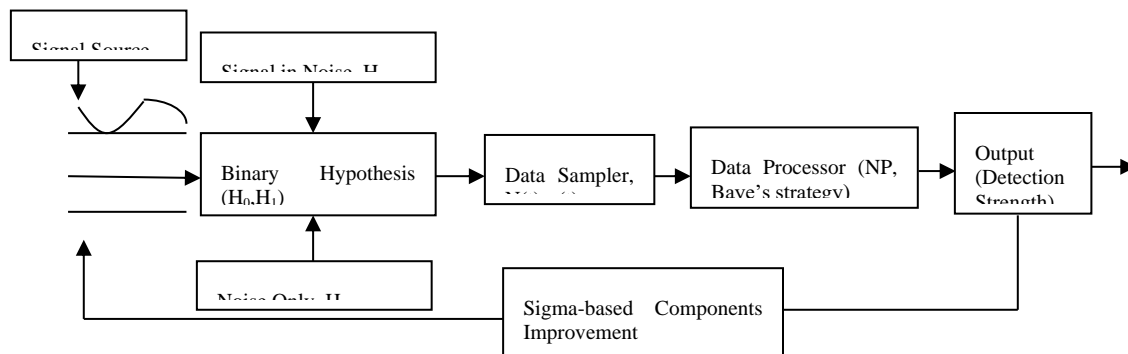

**Figure 1: System elements of signal detection-enhancement**

The developed algorithm was tested using data obtained from a detector (Lawal, 2102); whose detailed circuit is shown in Figure 2. It was incorporated with buzzer for signal detection as indicator (alert).

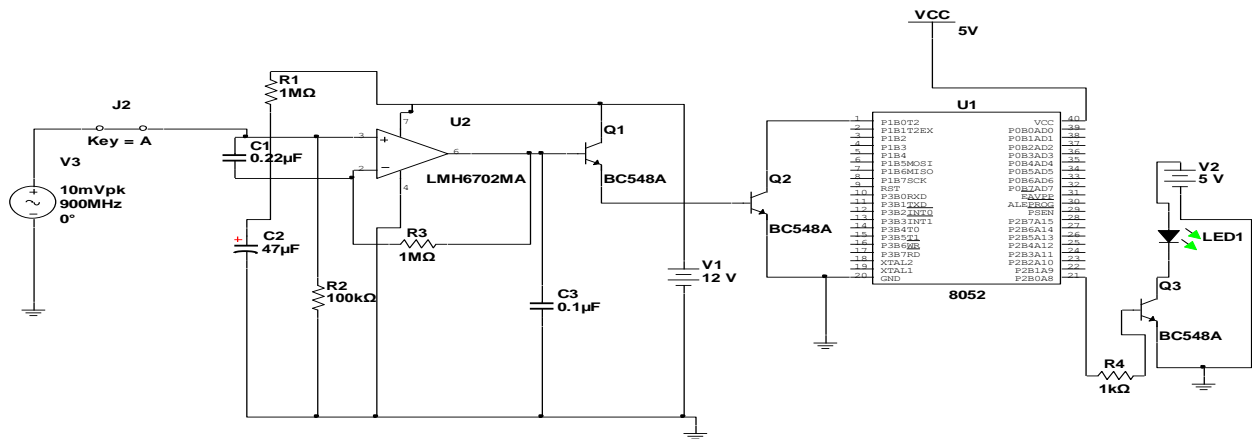

**Figure 2: Detector circuit with buzzer and microcontroller**

Based on Figure 1 experiment, signal detection enhancement modeling was carried out using the framework shown in Figure 3 using Signal detection statistics with improvement.

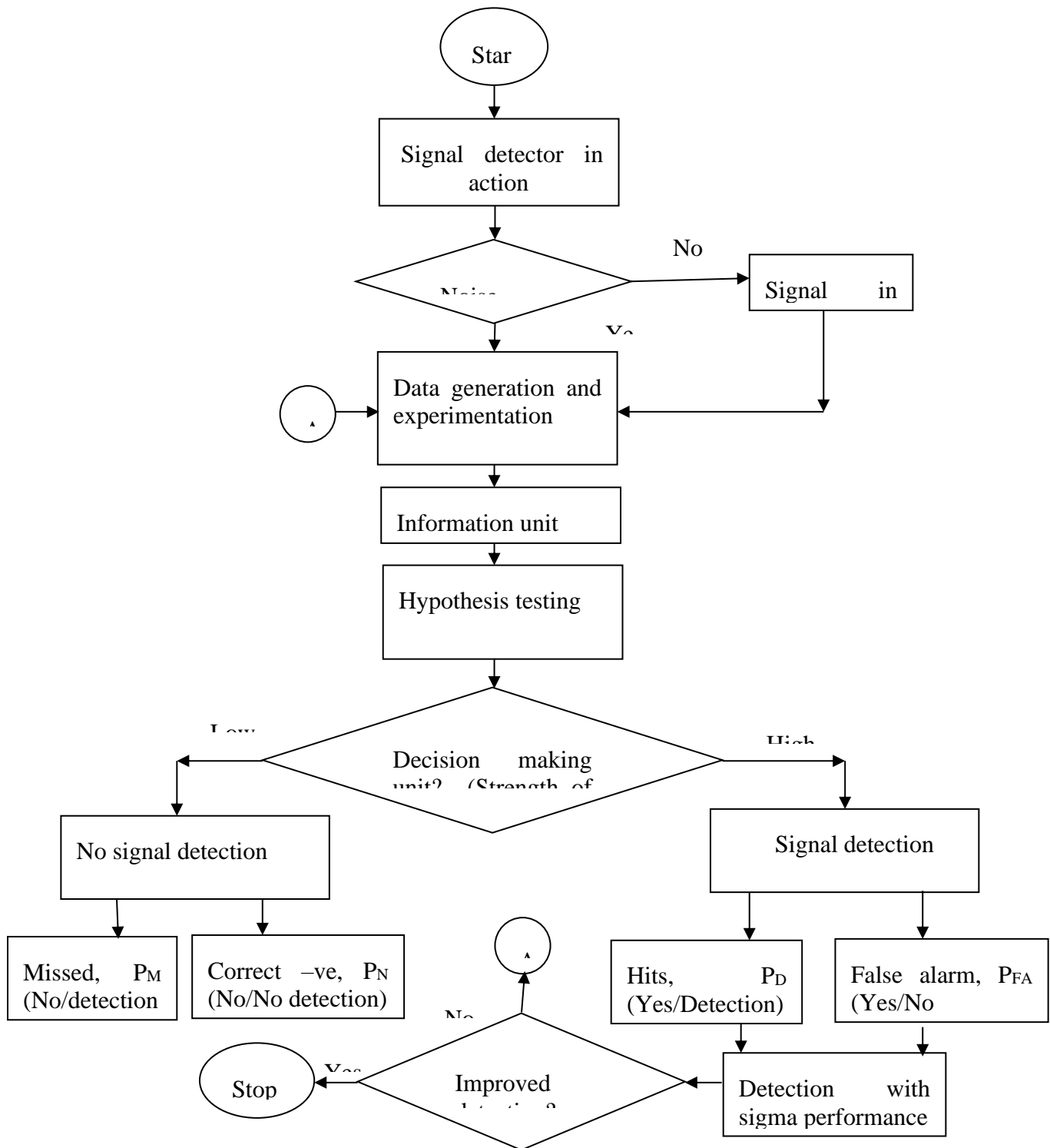

Figure 3: Signal detection statistics with improvement



### 3.1 Signal Detection under Noise Model

Parameters set for optimal cell-phone signal detection under noise are choices based on target not met/only noise present, or target met/signal detected revealed below. These are referred to as binary hypotheses. The choices are respectively represented by parameters  $H_0$  and  $H_1$ , (Figures. 1 and 3). Hence, the output,  $H_0$  or  $H_1$  will form the criteria for making decisions (Figure 3). Therefore, each time the experiment is conducted one of four scenarios can happen:

$P(H_0: H_0)$  = Prob. (decide  $H_0$  when  $H_0$  is true), Prob. of correct non-detection

$P(H_0: H_1)$  = Prob. (decide  $H_0$  when  $H_1$  is true), Prob. of missed detection  $P_M$

$P(H_1: H_1)$  = Prob. (decide  $H_1$  when  $H_1$  is true), Prob. of detection  $P_D$ .

$P(H_1: H_0)$  = Prob. (decide  $H_1$  when  $H_0$  is true), Prob. of false alarm  $P_{FA}$

In this study, the two criteria of interest are  $P_D$  and  $P_{FA}$  which will be operated upon using modified Bayes' and/or Neyman-Pearson (NP) approaches (Kay, 1998; Van, 2001; Kay, 1993; Vaseghi 2000). On this basis  $P_D$  and  $P_{FA}$  are represented as:

$$P_D = Q\left(\frac{\sqrt{\sigma^2/N}Q^{-1}(P_{FA}) - A}{\sqrt{\sigma^2/N}}\right)$$

$$P_D = Q\left(Q^{-1}(P_{FA}) - \sqrt{\frac{NA^2}{\sigma^2}}\right) \quad (1)$$

It is seen that for a given  $P_{FA}$  the detection performance would increase monotonically with  $NA^2/\sigma^2$ , which is the signal energy-to-noise ratio (ENR). In case of hypothesis testing based on mean-shifted Gauss-Gauss problem, it can be observed that the value of a test statistic  $T$  is determined by deciding  $H_1$  if  $T > \gamma'$  and  $H_0$  if otherwise as:

$$T \sim \begin{cases} N\left(\mu_0, \frac{\sigma^2}{N}\right) & \text{under } H_0 \\ N\left(\mu_1, \frac{\sigma^2}{N}\right) & \text{under } H_1 \end{cases}$$

where  $\mu_1 > \mu_0$ . Hence, this decides between the two hypotheses that differ by a shift in the means of  $T$ . Nevertheless, if  $T = \bar{x}$ , then the detection performance is totally characterized by the deflection coefficient  $d^2$  (Kay, 1998).

This is defined as

$$d^2 = \frac{(E(T; H_1) - E(T; H_0))^2}{\text{var}(T; H_0)} \quad (2)$$

$$= \frac{(\mu_1 - \mu_0)^2}{\sigma^2}.$$

In this case  $\mu_0 = 0$ ,  $d^2 = \mu_1^2/\sigma^2$  is interpreted as a signal-to-noise ratio (ENR).

Using:

$$P_{FA} = \Pr\{T > \gamma'; H_0\}$$

$$= Q\left(\frac{\gamma' - \mu_0}{\sigma}\right)$$

$$P_D = \Pr\{T > \gamma'; H_1\}$$

$$= Q\left(\frac{\gamma' - \mu_1}{\sigma}\right)$$

Equation (1) can be represented as (3)

$$= Q\left(Q^{-1}(P_{FA}) - \left(\frac{\mu_1 - \mu_0}{\sigma}\right)\right) \quad (3)$$

By replacing  $NA^2/\sigma^2$  with  $d^2$ , equation (1) can also be rewritten as (4)

$$P_D = Q\left(Q^{-1}(P_{FA}) - \sqrt{d^2}\right) \quad (4)$$

Since  $\mu_1 > \mu_0$  the detection, performance is therefore monotonic with the deflection coefficient. Each point on the curve corresponds to a value of  $(P_{FA}, P_D)$  for a given threshold  $\gamma'$ . By adjusting  $\gamma'$ , any point on the curve may be obtained. As expected as  $\gamma'$  increases,  $P_{FA}$  decreases but also does  $P_D$ . This type of performance summary is called the Receiver Operating Characteristics (ROC). However, the increment in  $P_D$  can be made independent of  $\gamma'$  by deploying component based sigma-quality improvement algorithm. This is the novelty introduced to the traditional model. This was carried out by proposing a total quality improvement system on critical components responsible for signal detection, namely, capacitors, transistors, resistors, amplifier and antennae (Figure. 2). Other components including detector casing, buzzer and display units are not critical because they do not have direct effect on detection. The latter components are considered to be connected in series to satisfy the criticality condition that failure of any one of them at time t can lead to total failure of the system. On this basis, improvement strategies based on sigma ( $\delta$ ) process quality were utilized on components for minimizing failure probability. The expected probability of detection  $P_b$  under standard process quality improvement system  $\delta_s$  based on probability  $Q$  (threshold) of not exceeding the targeted signal is given in absolute of:

$$P_{D_s} = Q\left(Q^{-1}(P_{FA} \delta_s) - \sqrt{d^2}\right) \quad (5)$$

where,  $s$  is counter for standard process quality deviation parameters varies from 1,2,3,...,6.

Signal strength termed signal Energy-to-Noise Ratio (ENR) was estimated as the absolute ratio of probabilities of detection and the false alarm and is expressed as:

$$ENR_s = \{Q\left(Q^{-1}(P_{FA} \delta_s) - \sqrt{d^2}\right)\} / P_{FA} \quad (6)$$

Equation (6) integrates probability of detection, probability of false alarm and signal energy-to-noise ratio with the components sigma quality improvement system for robust filtering of noises from the system. With this new algorithm, optimal signal detection can be evaluated without recourse to threshold value adjustment of the traditional Receiver Operating Characteristics (ROC). It is also important to assess the economic impact of the improvement process of critical components based on failure rate reduction. On this basis, figure 4 represents block diagram of series critical components interrelationship of the detector. It comprises capacitor, resistor, transistor, operational amplifier and antenna with failure rates  $\lambda_1, \lambda_2, \lambda_3, \lambda_4,$  and  $\lambda_5$  respectively, with overall failure rate ( $\lambda$ ).

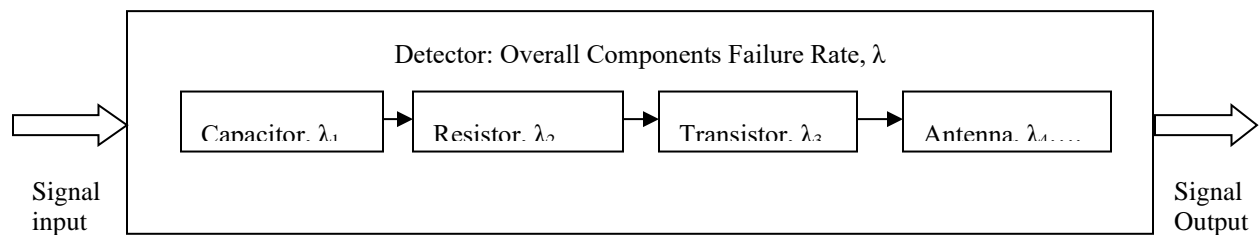

**Figure 4: Detector’s critical components relationship**

Under exponential distribution, probability that the detector system will survive beyond time,  $t$  is given equation (7)

$$R(t) = e^{-(\lambda_1 t + \lambda_2 t + \lambda_3 t + \lambda_4 t + \lambda_5 t)} \tag{7}$$

where,  $R(t)$ , is the system reliability, Eqn. (7) can be rewritten as Eqn. (8) if detector components exhibit similar failure rate.

$$R(t) = e^{-5\lambda t} \tag{8}$$

Eqn. (8) is measurable using Eqn. (5) based on probability of detection at a given time  $P_D(t)$ .

The corresponding failure probability  $P_F(t)$  is given as:

$$P_F(t) = 1 - e^{-5\lambda t} \tag{9}$$

From Eqn. (9) component failure rate  $\lambda$  can be determined by taking natural logarithm as:

$$\lambda = \frac{-\ln\{1 - P_F(t)\}}{5t} \tag{10}$$

Then, for uniformly distributed data, Eqn. (10) becomes Eqn. (11) (Gordon, 1992);

$$\lambda = \frac{-0.2 \ln\{P_F(t)\}}{t} \tag{11}$$

$P_F(t)$  is determined from detection probability outcomes in Eqn. (5) based on sigma quality  $\delta_s$  by partitioning it based on reliability/failure of critical components responsible for detection using heuristic based on mixed integer programming (MIP). This is expressed as follows:

$$P_F(t) = \frac{\sum P_{D0}}{\sum P_{D0} + \sum P_{D1}} \tag{12}$$

That is:  $P_{D0}=0$ , for signal strength failure part  $P_D \leq 0.5$ ; and  $P_{D1}=1$ , otherwise, that is,  $P_D > 0.5$ .

Eqn. (12) is significant because it determines the optimal standard process sigma quality level that could minimize components failure rate. The outcomes of analysis of Eqn. (12) could address the following; identify components' sigma level of experimental detector (having the same characteristics), and determine components' sigma level corresponding to optimal detector circuitry design.

### 3.3 Model Implementation

Data from a cell-phone signal detector (Figure 3) was used to implement the model. The data collected were analyzed based on general detector behaviour with probabilities of false alarm ranging from 0 to 1. This indicated that when false alarm is 0, there is full (accurate) signal detection and if false alarm is 1, then detector is not functioning well. Reduction of false alarms was carried out by introducing component-based sigma improvement strategies varied from one (1) to six (6) sigma-quality under homogeneous behaviour of the system. In this arrangement, the standard sigma quality range 0.69 to 0.0000034 would have reduced circuitry system failure probabilities to a manageable level (Kareem, 2015; OEC, 2015). The probability of exceeding the given value (target)  $Q(x)$ , was ranged 0 to 1. The distance (d), called deflection coefficient between means of the two densities of hypothesis ( $H_0$ ,  $H_1$ ) was taken in the range 0.5 to 2.0 in step of 0.5 for clear visualization of trends. Analysis of the optimized detection system was carried out on MATLAB computer software to determine the effect of sigma improvement system on the signal detection, and signal energy-to-noise ratio (ENR) performance. The detection results generated based on stated variation of input parameters are presented in figures 5-11 for detection probabilities and signal energy-to-noise ratio performance respectively. The results of further components' failure analysis of the experimental detector in an attempt to identify its sigma level and that of the proposed improved detectors are presented in Tables 1a,b and figure 12. This sigma level identification of component was not done in the previous study.

### 4.0 FINDINGS AND PRESENTATIONS

The results based on balanced probability of not exceeding the target of 0.5 were generated to illustrate performance of the system in terms of signal detection accuracy of the system using sigma circuitry systems as improvement tools (Figure 5). Figure 5 a,b show probability level of signal detection improvement with deflection coefficient between signal and noise interaction using balanced probability of meeting target (0.5). The corresponding performance based on signal detection probability and signal energy-to-noise ratio (ENR) is given in figure 5a,b. It can be seen from the stated results (Fig. 5a,b.) that for a given probability of false alarm ( $P_{FA}$ ), the detection performance increases monotonically with the ENR. This followed the traditional law. These outcomes indicated a good performance of the system (Kay, 1998; Van, 2001; Kay, 1993). Figures 6-11(a,b) revealed detection probability and ENR performance outcomes when component-based sigma quality improvement system was utilized. The results obtained based on one-sigma (Figures 6a, b.) indicated a slightly improved signal detection probability over that of experimental detector (Fig. 5a,b.). Steadily and more satisfactorily improved signal detection performances were noticed at varying degrees under two-, three-, four-, five-, and six-sigma

quality (Figures 7-11). The stated results showed the superiority of six-sigma component-based quality in exhibiting highest performance in signal detection and signal energy-to-noise ratio (Fig. 11a,b). Higher sigma level detector demands the determination of alternative sigma quality detector that could serve at similar capacity and has been done and results presented in tables 1a and b and figure 12 respectively.

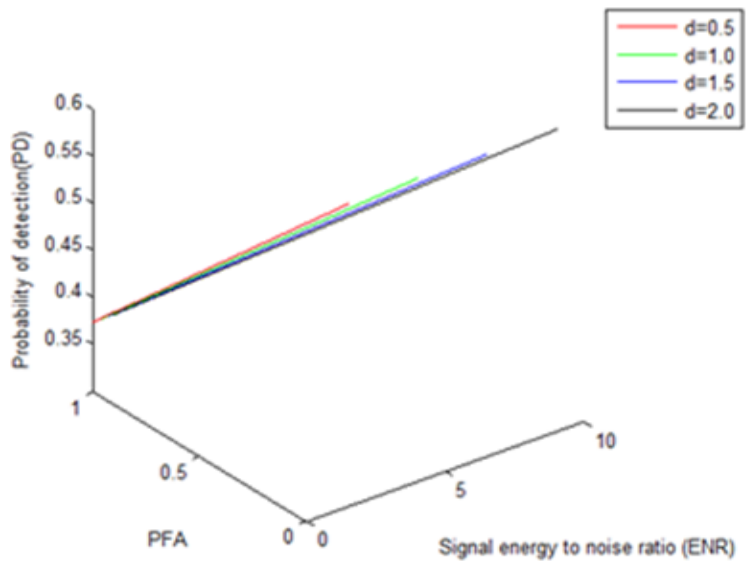

**Figure 5a: Detection trend without sigma improvement system**

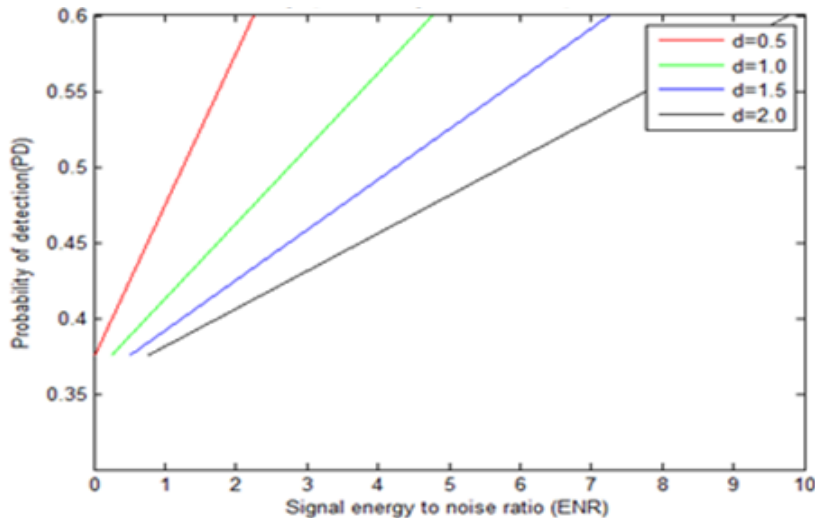

**Figure 5b: Signal Detection Strength without sigma improvement system**

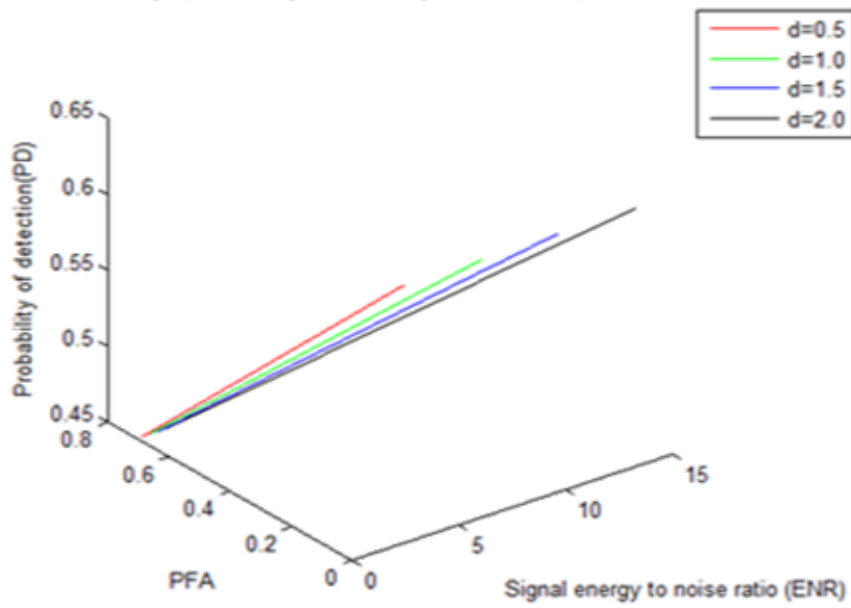

Figure 6a: Detection trend with one-sigma improvement system

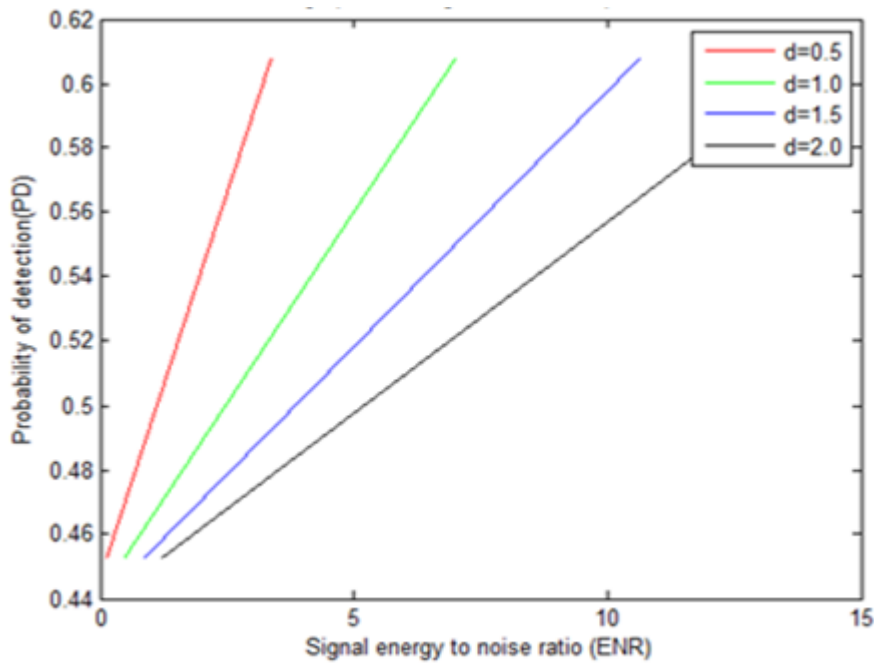
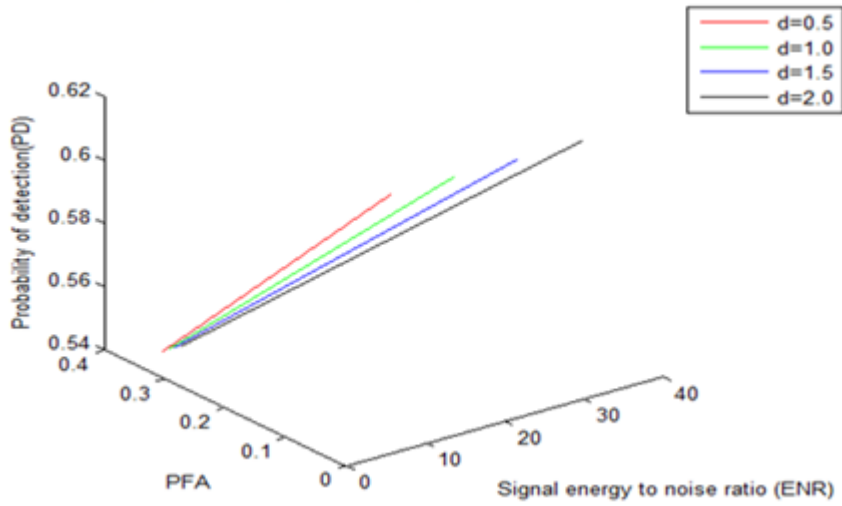
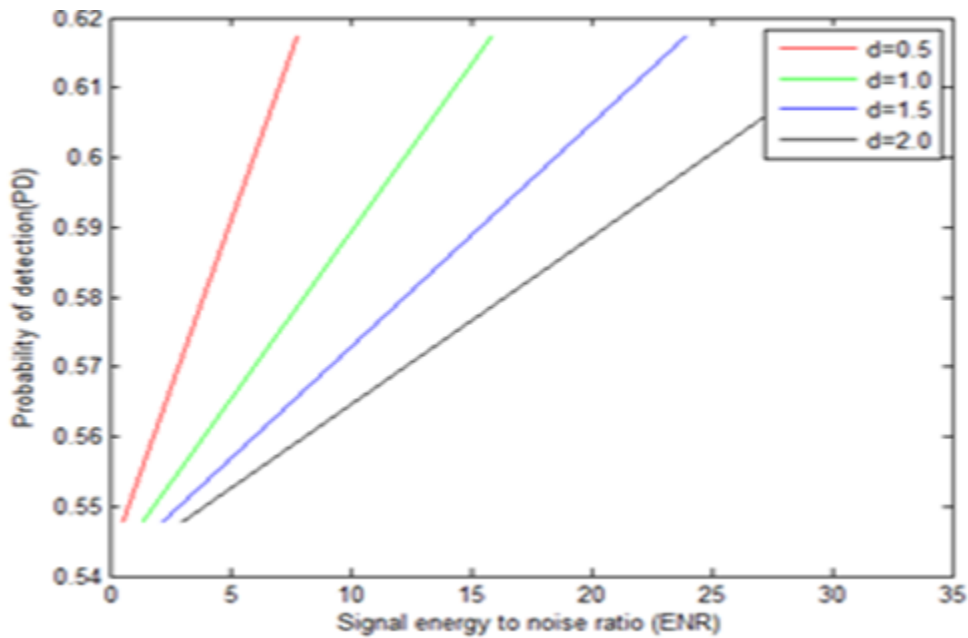

Figure 6b: Signal detection strength with one-sigma improvement system



**Figure 7a: Detection trend with two- sigma improvement system**



**Figure 7b: Signal detection strength with two- sigma improvement system**

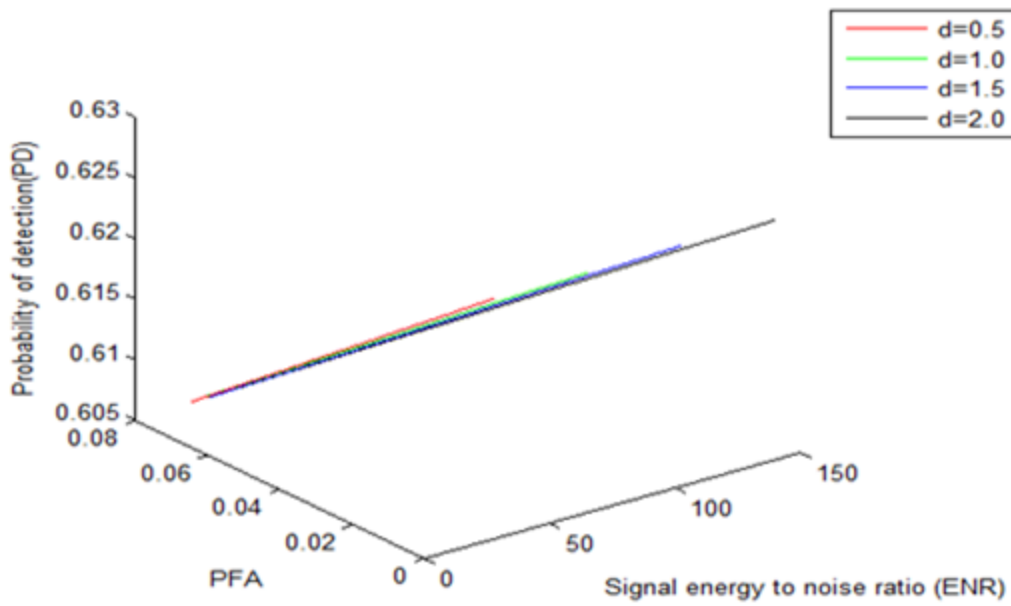

Figure 8a: Detection trend with three- sigma improvement system

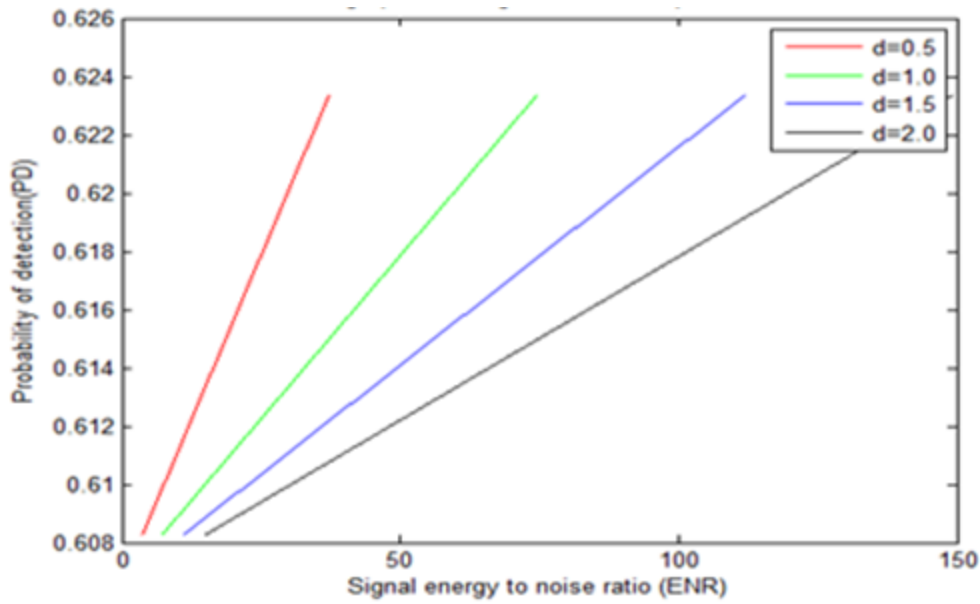

Figure 8b: Signal detection strength with three- sigma improvement system



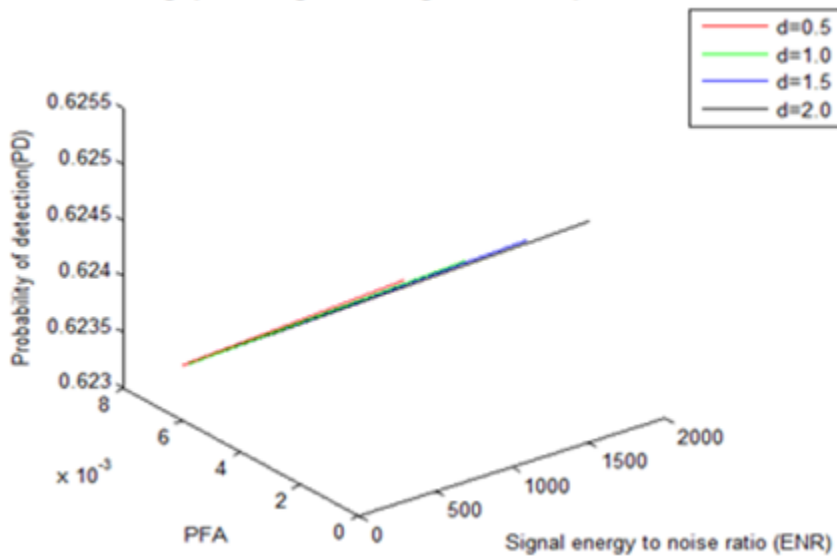

Figure 9a: Detection trend with four-sigma improvement system

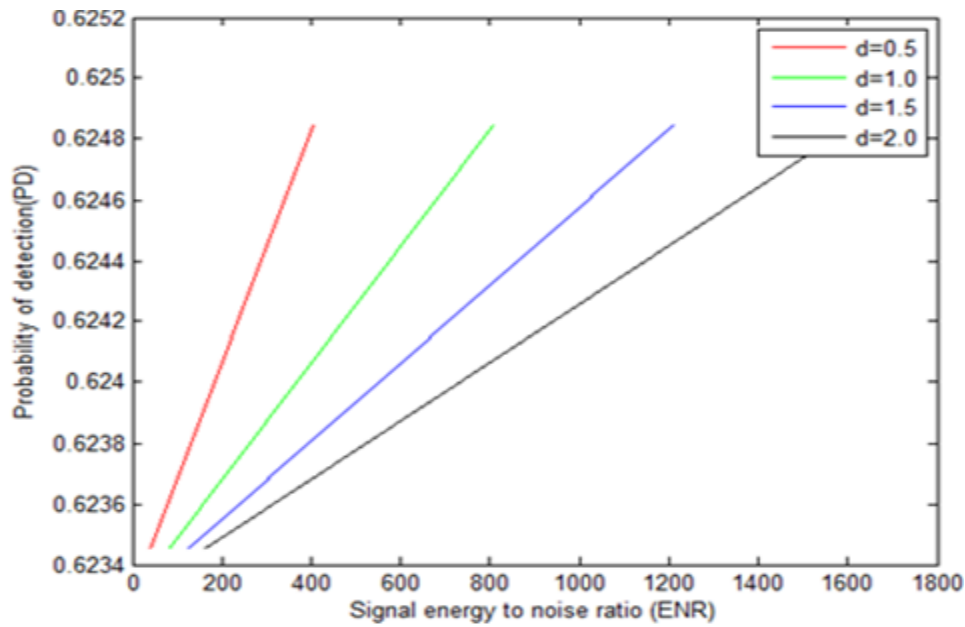

Figure 9b: Signal detection strength with four-sigma improvement system

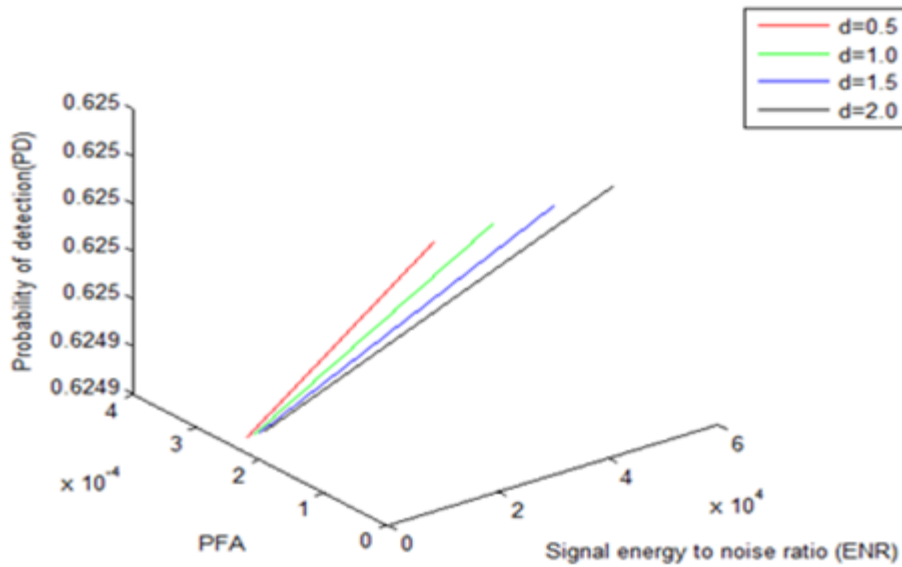

Figure 10a: Detection trend with five-sigma improvement system

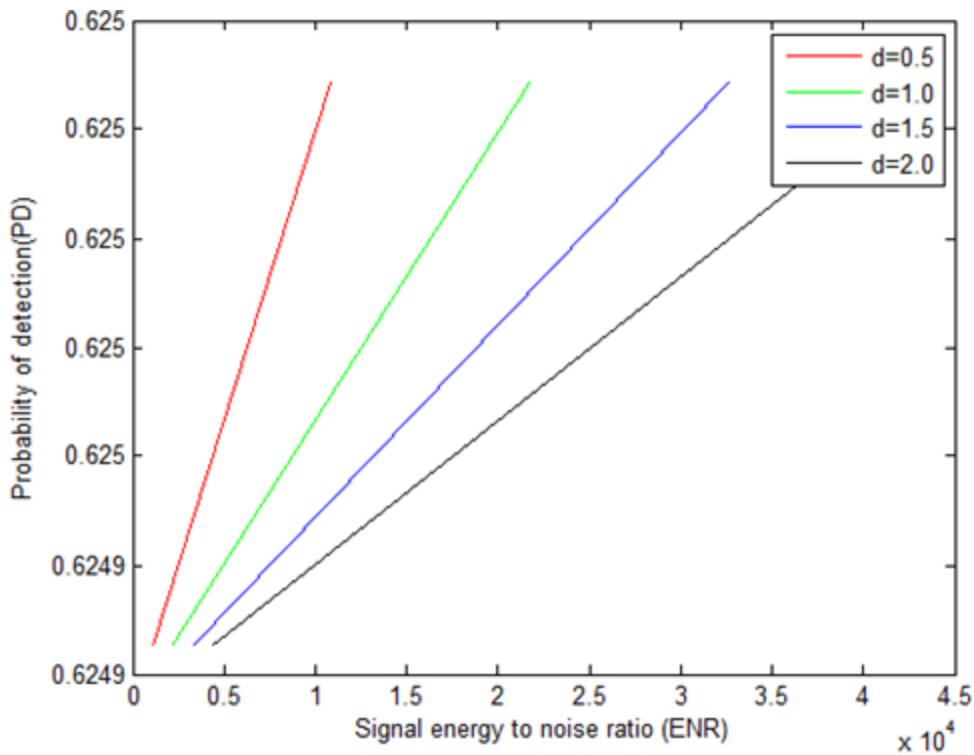
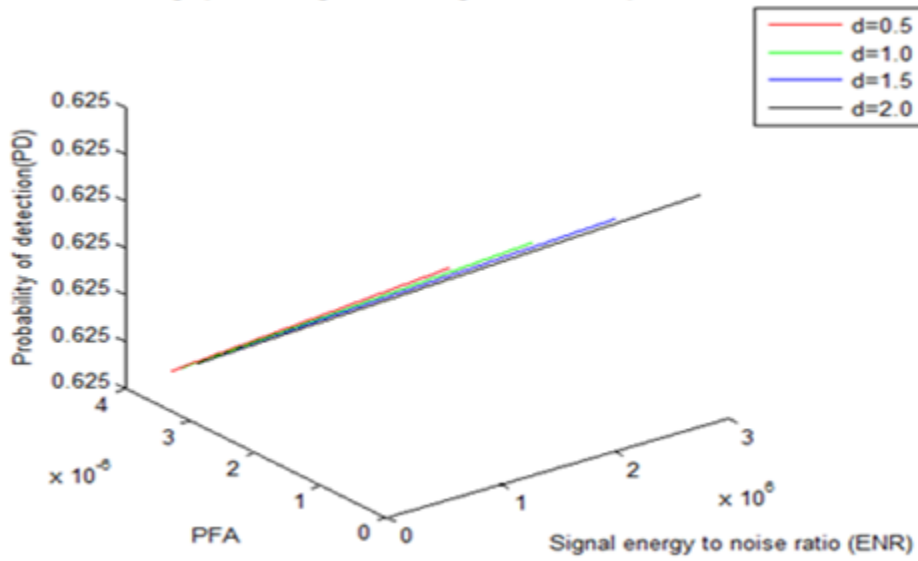
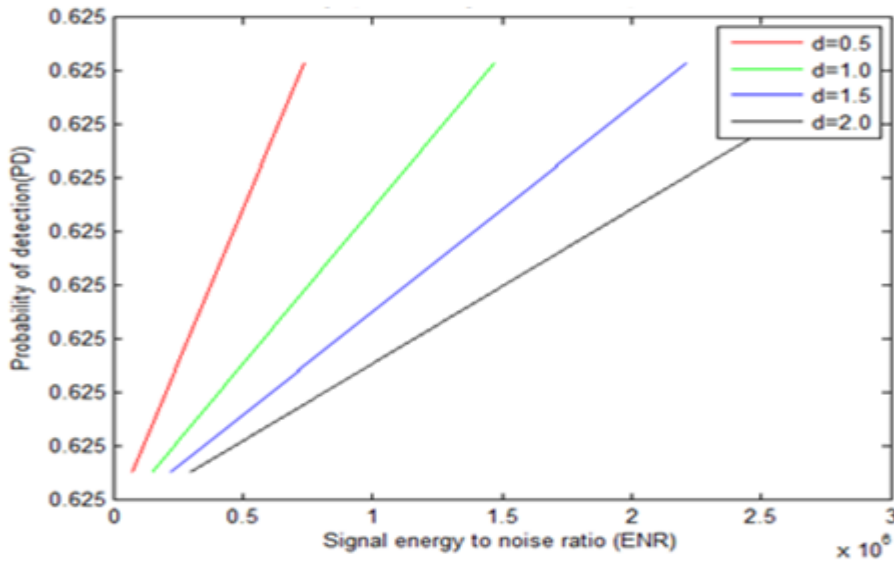

Figure 10b: Signal detection strength with five-sigma improvement system



**Figure 11a: Detection trend with six-sigma improvement system**



**Figure 11b: Signal detection strength with six-sigma improvement system**

The results obtained based on the detector's critical components' failure rate analysis were presented in Table 1a and Table 1b and Figure 12.

**Table 1a: Critical Component's Failure Probability**

$\delta_s$	$P_{D0}$	$P_{D1}$	$P_{D0} + P_{D1}$	$P_{D0} / (P_{D0} + P_{D1})$	$P_F(t)$	Failure rate, $\lambda$
0	5	5	10	5/10	0.5	0.173
1	4	6	10	4/10	0.4	0.128
2	4	6	10	4/10	0.4	0.128
3	0	10	10	0/10	0	0
4	0	10	10	0/10	0	0
5	0	10	10	0/10	0	0
6	0	10	10	0/10	0	0

**Table 1b: Critical component's failure rate characteristics**

$P_F(t)$							
$t$	$\delta_0$	$\delta_1$	$\delta_2$	$\delta_3$	$\delta_4$	$\delta_5$	$\delta_6$
1	0.1730	0.1280	0.1280	0	0	0	0
2	0.0865	0.0640	0.0640	0	0	0	0
3	0.0577	0.0427	0.0427	0	0	0	0
4	0.0432	0.0320	0.0320	0	0	0	0
5	0.0346	0.0256	0.0256	0	0	0	0
6	0.0288	0.0213	0.0213	0	0	0	0
7	0.0247	0.0183	0.0183	0	0	0	0
8	0.0216	0.0160	0.0160	0	0	0	0
9	0.0192	0.0142	0.0142	0	0	0	0
10	0.0173	0.0128	0.0128	0	0	0	0

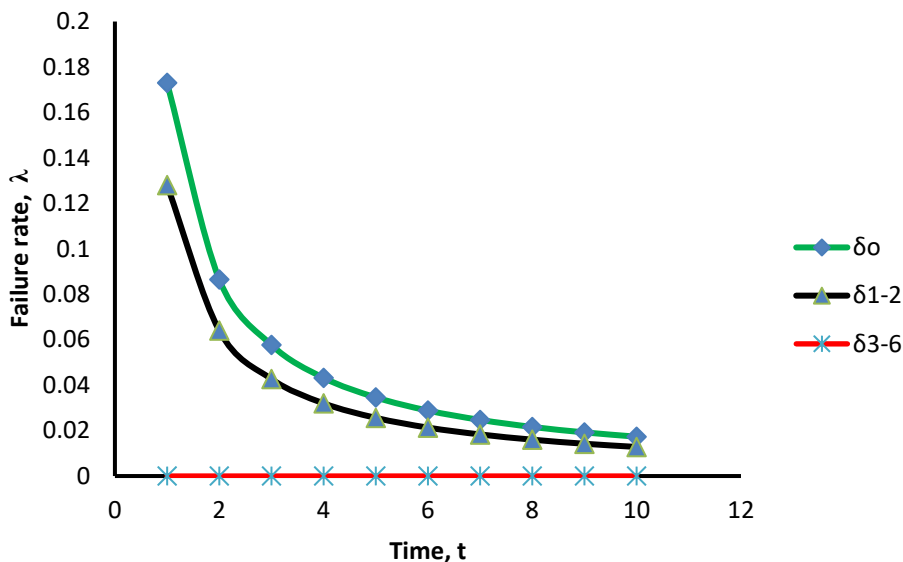

**Figure 12: Critical component's failure rate at sigma levels**

## 5.0 SUMMARY OF FINDINGS, CONCLUSIONS AND RECOMMENDATIONS

### 5.1 Summary of the findings

Tables 1a and 1b and Figure 12 respectively revealed the results of experimental detector at one and two-sigma quality based detection exhibited with similar failure rate characteristics, 0.173, 0.128 and 0.128 respectively (Table 1a). The critical components of the experimental detector appear to be failed at the beginning of the design/operation life and later stable with lower failure rates. It was further investigated that a detector of high precision and accuracy could be achieved with critical components designed beyond two-sigma quality level. However, detector of three-sigma design was selected as being optimal to take care of unknown condition. The outcomes generally revealed that signal detection performance could be improved upon through effective component refinement approach (quality adjustment/quality calibration) (Pyzdek, 2003; Nonthaleerak and Hendry 2006; Kareem, 2015; OEC, 2015; Kareem and Jewo 2015; Ogunti et al 2015a, 2015b; Hadi-Vencheh, and Yousefi, 2018).

### 5.2 Conclusions

The design that relates system elements of signal detection enhancement circuitry has been carried out. The detection circuit was developed to take care of deficiencies in the previous detection circuitries in the area of signal detection enhancement through incorporation of component-based sigma improvement system. Signal detection enhancement modeling was developed using the improvement flow system strategy. It can be generally concluded from the results of the study that

signal detection could be fully enhanced with the application of six sigma component-based improvement system. However, the deployment of six sigma system may demand high cost of detection. One cannot conclude yet on the high cost of detection until thorough analysis of the cost of risk of missing targets through increased probability of false alarm is carried out. The outcomes of the study generally revealed that signal strength could be fully enhanced with the application of six-sigma component-based quality system. Signal strengths based on signal energy-to-noise ratios were running into thousands while the probabilities of false alarms were running close to zero with the application of six-sigma quality scheme. The outcomes have demonstrated a promising approach to effective noise removal from the communication systems and through the application of a component-based sigma-quality. The system reliability and availability can be improved using sigma-quality enhancement strategy as investigated. The outcomes of this study have filled some gaps in the existing theory and practice in the area of integration of sigma component reliability techniques.

## 5.2 Recommendations

The following areas can be further explored:

- i. determination of profitable course of action through balancing the cost of improved detection accuracy and cost of missing targets due to increased false alarm could be a good research area in future.
- ii. utilizing the established procedures in ascertaining quality of signal detectability of any given system to warrant prediction of failure and improvement strategy.

## Abbreviations

ENR	Energy -to-noise-ratio
$P_{FA}$	Probability of false alarm
RF	Radio frequency
DSA	Dynamic spectrum access
$P_M$	Probability of missed detection
$P_D$	Probability of detection
NP	Neyman-Pearson
PDF	Probability density function
WGN	White Gaussian Noise
$d$	Deflection coefficient
CDF	Cumulative distribution function
SNR	Signal-to-noise ratio
ROC	Receiver operating characteristics
TQIM	Total quality instrumentation management

**Competing interests** The authors declare that there is no competing interest.

**Acknowledgements** The authors wish to express gratitude to the Managements of the Federal University of Technology, Akure, and Rufus Giwa Polytechnic, Owo, Nigeria, for providing necessary facilities for this study.

## References

- Adeyuyi, O.S., Lawal, W., and Ogunti, E.O. (2013). Performance Analysis of OFDM in Combating Multipath Fading. *IOSR Journal of Electronics and Communication Engineering (IOSR-JECE)*, 6 (2) 99-107
- Arshed, A., Muhammad, S., Noor, G., Irfan, U., Su, M. and Junsu, K. (2020). A comparative Analysis of Different Outlier Detection Techniques in Cognitive Radio Networks with Malicious Users. *Hindawi Journal of Wireless Communications and Mobile Computing* Volume 2020, Article ID 8832191, <https://doi.org/10.1155/20208832191>.
- Broumandan, A. (2009). *Enhanced narrowband signal detection and estimation with a synthetic antenna array for location applications* (Doctoral dissertation, University of Calgary, Department of Geomatics Engineering).
- Chaouech, H. and Bouallegue, R. (2012). Multiuser Detection in Asynchronous Multibeam Communications. *Inter. Journal of Wireless & Mobile Networks (IJWMN)* 4 (1) 21-34
- Dece, K.M. (2012). Novel Mobile Detector Sensing Alarming and Reporting System. *ARPJ Journal of Science and Technology*, 2 (1) 12-14
- Gordon, G. (1992). *System Simulation*, Prentice-Hall, New Delhi.
- Hadi-Vencheh, A. and Yousefi, A. (2018). Sigma Project: a comparative study of DEA and LDA techniques, *International Journal of Lean Six Sigma*, ISSN 20404166
- Kaemarungsi K. and Krishnamurthy P. (2004): *Modeling of Indoor Positioning Systems Based on Location Fingerprinting*. In Proceedings IEEE INFOCOM 2004. 3-4 November.
- Kailath, T. and Poor, H.V. (1998). Detection of Stochastic Processes. *IEEE Transactions on Information Theory*, 44 (6) 2230-2259
- Kareem, B. (2015). Evaluation of Failures in Mechanical Crankshafts of Automobile based on Expert Opinion, *Case Study in Engineering Failure Analysis*, 3(1) 25-33
- Kay, S.M. (1993). *Fundamental of Statistical Signal Processing- Estimation Theory*, Prentice Hall, New Jersey
- Kay, S.M. (1998). *Fundamental of Statistical Signal Processing-Detection Theory*, Prentice Hall, New Jersey
- Kundu, D (2000). Estimating the Number of Signals In The Presence of White Noise. *Journal of Statistical Planning and Inference*. 90 (1) 57- 68
- Lau, Y. W (2008). Noise in Accounting Information. The Signal Detection Theory Perspective. *Int. Journal of Economics and Management* 2(1). 179 – 193

- Lawal, W (2012). Development of Unauthorized Cell-Phone Usage Sniffing System. A Thesis Submitted to the School of Postgraduate Studies in Partial Fulfillment of the Requirements for the Degree of Master's in Engineering in Electrical and Electronics Engineering, the Federal University of Technology, Akure, Nigeria, December 2012
- Lawal, W. and Ogunti, E.O (2012). An Evaluation of Mobile Phone usage Restriction in Selected Public Places in Akure, Nigeria. Book of Proceedings, 4<sup>th</sup> International Conference on Engineering research and Development (ICERD 2012), University of Benin, Benin City, Nigeria.
- Lawal, W., Adewuyi, S. O., and Ogunti E.O (2014). Effect of Cyclic Prefix on OFDM over AWGN Channel. *International Journal of Innovative Research in Advanced Engineering (IJIRAE)*, 1 (9) 185-191
- Lawal, W., Akinrinmade, A.F., and Ijarotimi, S. O (2013). Effects of Unrestricted Mobile phone Usage in Selected Public Places in Nigeria. A Case Study of Akure. *International Journal of Science and Research (IJSR)*, 2 (5) 224-228
- Lawal, W., Oluwajobi, F.I .and Ogunti E.O (2014). Development of Unauthorized Cell-phone Usage Sniffing System using Embedded System. Proceedings of the International Conference on Advances in Computing, Electronics and Electrical technology- CEET 2014, pp. 208-212.
- Mantoro T., Olowolayemo, A., Olatunji, S. O, Bahru, J., Ayu, M. A. and Osman, A. (2011): Extreme learning machine for user location prediction in mobile environment Tap *International Journal of Pervasive Computing and Communications* 7(2), pp.162-180 Emerald Group Publishing Limited 1742-7371 DOI 10.1108/17427371111146446
- Mantoro, T. and Olowolayemo, A. (2009): Mobile user location prediction enabled services in Ubiquitous computing: determining user location using MFN algorithm", Proceedings of the 11th International Conference on Information Integration and Web-based Applications and Services , Kuala Lumpur, Malaysia, 14-16 December.
- Nicholas, W.S (2011). Study of Cellular Phone Detection Techniques, M.Sc. Dissertation, Computer and electronics Engineering, Department of Dissertations & Student Research in Computer Electronics & Engineering, University of Nebraska-Lincoln.
- Nonthaleerak, P. and Hendry, L.C. (2006) Six Sigma: Literature Review and Key Future Research Areas, *International Journal Six Sigma and Competitive Advantage* Vol.2, No.2, pp 105-161.
- O'shea, T.J., Clancy, T.C., and Ebeid, H.J (2014). Practical Signal Detection and Classification in Gnu Radio. *Research Conducted at Laboratory for Communication Sciences, US Department of Defense*.
- Pastor, D. and Socheleau, F.X (2012). Algorithms Based On Sparsity Hypotheses For Robust Estimation of the Noise Standard Deviation in Presence of Signals with Unknown Distributions and Occurrences. Collection des rapports de recherché de Telecom Bretagne, RR-2010001-SC, hal-00703291, version 1-1 June 2012, Telecom Bretagne, France.



- Pyzdek, T. (2003). *The Six Sigma Handbook*, McGraw-Hill, New York,
- Saberali, S.M. and Amindavar, H (2007). Spread Spectrum Signal Detection in Overlay Systems Using Maximum Entropy PDF Estimation Based on Fractional Moments, *IEEE ICASSP 2007*, III, pp. 1269-1272
- Shevlyakov, G. and Kim, K (2006). Robust Minimax Detection of a Weak Signal in Noise with a Bounded Variance and Density Value at The Center Of Symmetry. *IEEE Transactions on Information Theory*, 52 (3) 1206- 1211
- Six Sigma (2015). Operational Excellence consulting, [www.oeconsulting.com.sg](http://www.oeconsulting.com.sg). Accessed 11.12.
- Tandra, R (2005). Fundamental Limits on Detection in Low SNR. A Thesis Submitted in Partial Satisfaction of the Requirements for the Degree of Master of Science in Engineering, Electrical Engineering and Computer Sciences in the Graduate Division of the University of California, Berkeley, Spring.
- Tsai, C.Y., Chou, S. Y. Lin, S. W. and Wang, W. H. (2009): Location Determination of Mobile Device for Indoor WLAN Application using Neural Networks. In *Journal for Knowledge and Information Systems*, Springer London.
- Turner, B.M (2009). Signal Detection Theory. A Proposal for a Nonparametric Model. A Thesis Presented in Partial Fulfillment of the Requirements for the Degree Master of Arts in the Graduate School of the Ohio State University.
- Van Trees, H.L (2001). Detection, Estimation, and Modulation Theory, Part I. *Detection, Estimation, and Linear Modulation Theory*. pp. 19-86. John Wiley & Sons, Inc.
- Vaseghi, S.V., and Rayner, P.J.W (1990). Detection and Suppression of Impulsive Noise in Speech Communication Systems. *IEE Proceedings*, 137 (1) 38-46
- Veseghi, S.V (2000). *Advanced Digital Signal Processing and Noise Reduction, Second Edition*, pp. 356- 377. John Wiley & Sons Ltd.